

This drawing and the ideas, concepts, illustrative and written information represented thereby are the confidential and proprietary property of HYDROTHER. Reproduction of all or any part of this drawing or prints thereof, or any other unauthorized utilization of any confidential and proprietary property contained herein without the permission of HYDROTHER, is forbidden.

No.	Date	Description
1	Oct-19/11	Checked by BRB
Revisions		

HYDROTHER
135 MATHESON BLVD. E.
MISSISSAUGA, ONTARIO
CANADA
L4Z 1R2

www.hydrother.com

Project	
Title HYDROTHER Model H - 1100 C	
2015 Model Year	
Drawn By	ADB
Scale	n.t.s.
Date	Apr-03/12
Ch'd By	dp
Job No.	1

SHELL DIMENSIONS
Dimensions may differ up to 1/2" (1.27cm) between Spas. Exact measurements should be obtained from delivered unit.

LENGTH 120" [304.8cm] WIDTH 92" [233cm] HEIGHT 42.5" [108cm] VOLUME: @650 Gl / 2461 Lt WEIGHT EMPTY 950 lbs / 431 kg WEIGHT FULL 6371 lbs / 2890 kg SURFACE AREA 48 sq.ft [4.32sq.m]

All equipment UL and UL-C approved. All fittings N.S.F. and ANSI/ASME LISTED.

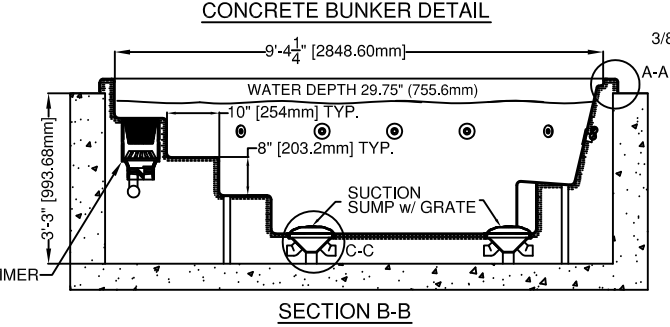
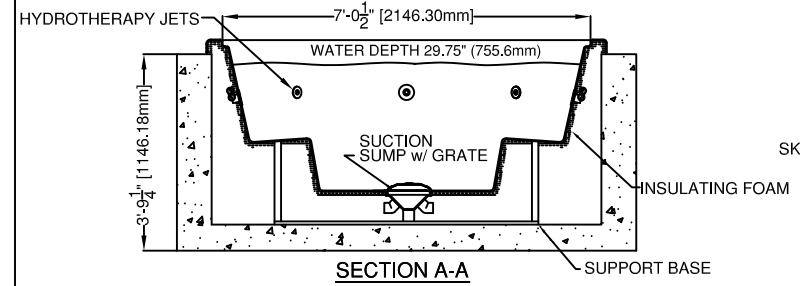
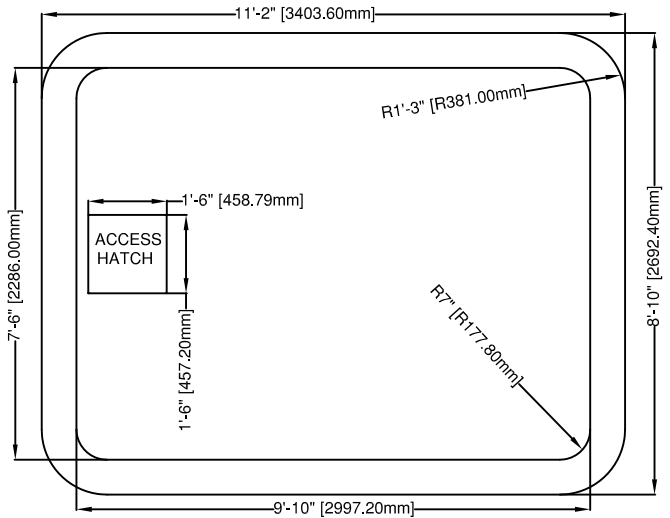
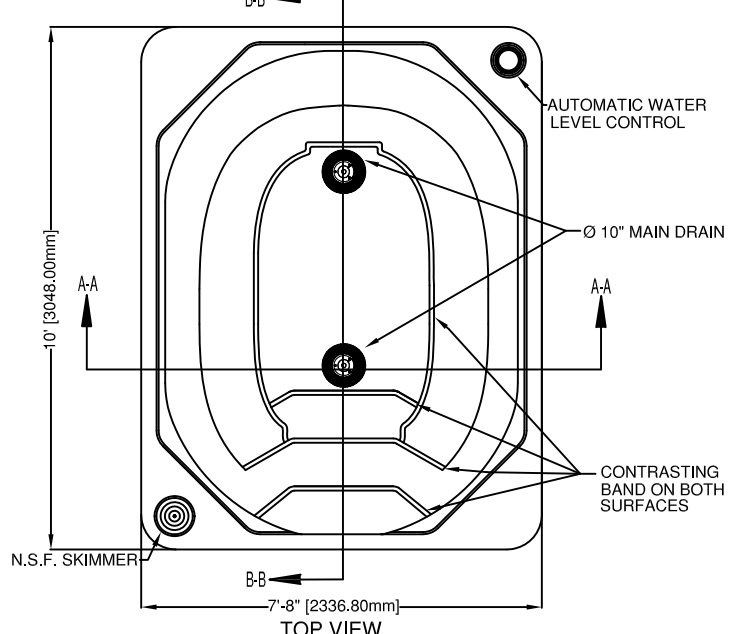

RIGID PLUMBING AVAILABLE AS UPGRADE

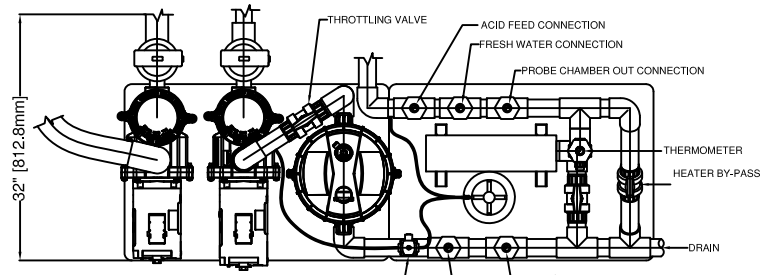
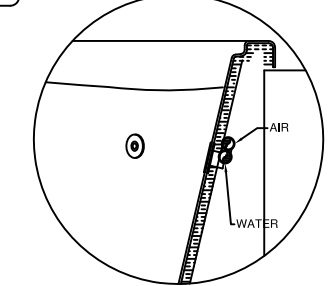
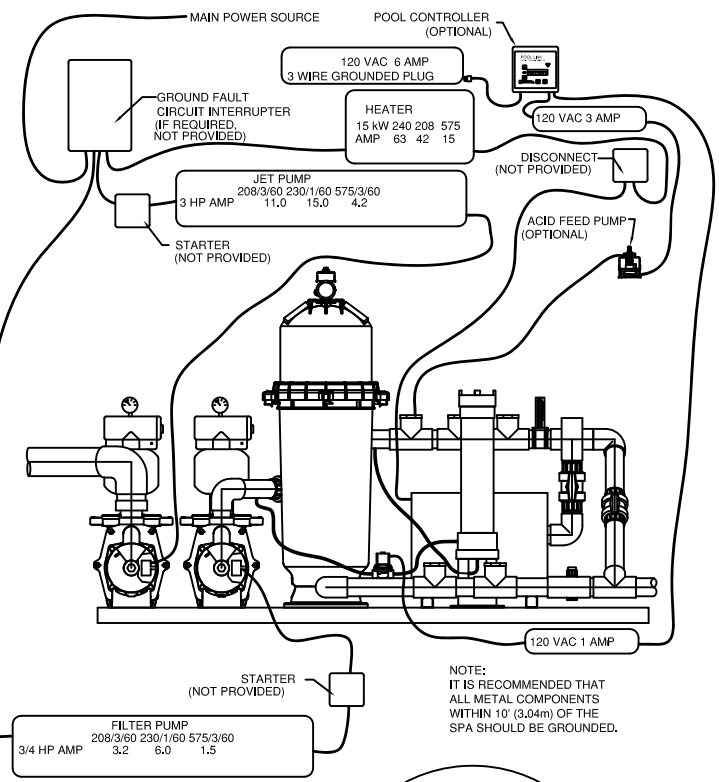
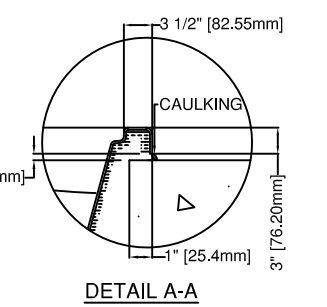
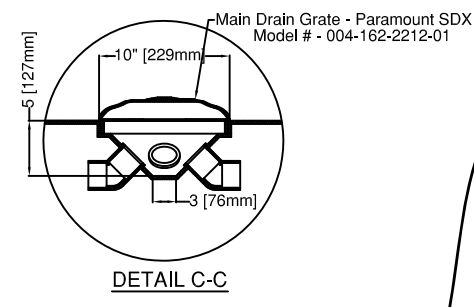

NOTE: Connections will only be present if the chemical control system option is selected

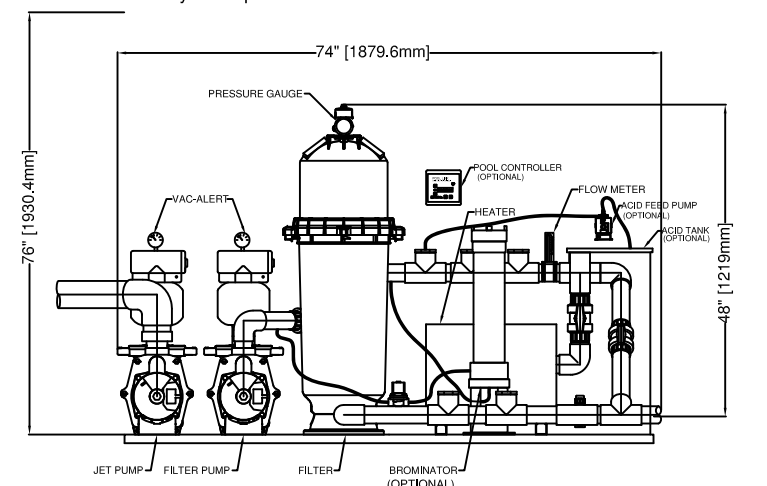

NOTE: Mechanical support systems requires a minimum top clearance of 76" to service the cartridge filter

SPECIFICATIONS

- The shell of the hot tub shall be manufactured of vacuum formed acrylic (.187 sheet) in the colour Biscuit (Ivory Bone) Hot tub shell overall dimensions: 120" x 92" x 42.5" deep. See dimensional information on this sheet.
- The acrylic shall be further reinforced with fiberglass resins but may require additional on-site bracing supports (customer's responsibility) under the steps and seats.
- The shell shall have the following fittings:
 - 7 Large hydrotherapy jets
 - 4 Medium hydrotherapy jets
 - 1 Wide mouth skimmer, (N.S.F. Listed)
 - 2 Built in bottom drain sumps with removable grate
 - 2 Air control valves
 - 1 Water level tank fitting with remote water level control tank
 - 3 Filtered water return inlets
- The hot tub will be insulated with a coating of polyurethane foam, factory plumbed and hydrostatically tested.
- Recommended HCSP-3 mechanical support system will be shipped on a separate plastic base and shall consist of:

QTY.

 - 3/4hp filter pump (N.S.F. Listed)
 - 150 sq.ft. cartridge filter N.S.F. Listed)
 - 3 hp hydrotherapy booster pump (N.S.F. Listed)
 - 15 kW electric heater c/w flow switch
 - 2 Inline thermometers c/w thermowell
 - 1 Inline flowmeter
 - 1 Water level controller with overflow (located at the shell)
- Optional Equipment

QTY.

 - Chemistry Control Pack (Optional)
 - Acid feed pump with 15 gal solution tank c/w lid (Optional)
 - 15 Minute timer for jet pump c/w contactor (Optional)
 - Audio/Visual alarm beacon (Optional)
 - Handrail with anchor and escutcheon plates or deck flange (Optional)
 - VA2000 Vacuum Release devices (ASME A112.1917-2002 Listed)(Optional)
- Warranties shall be 5 year on the shell structure, 2 years on the acrylic surface and one year on the plumbing, labor, accessories and parts. On-site plumbing is NOT covered.
- Installation items NOT covered by this specification and considered "by others" are Plumbing between the spa shell and mechanical equipment location. Electrical connections, motor, heater and component connections including motor starters, timers, push/pull switches, A/V alarm, grounding of all electrical components and GFCI's. Decking and access steps including deck drains. Supports under the seats and steps of the shell.

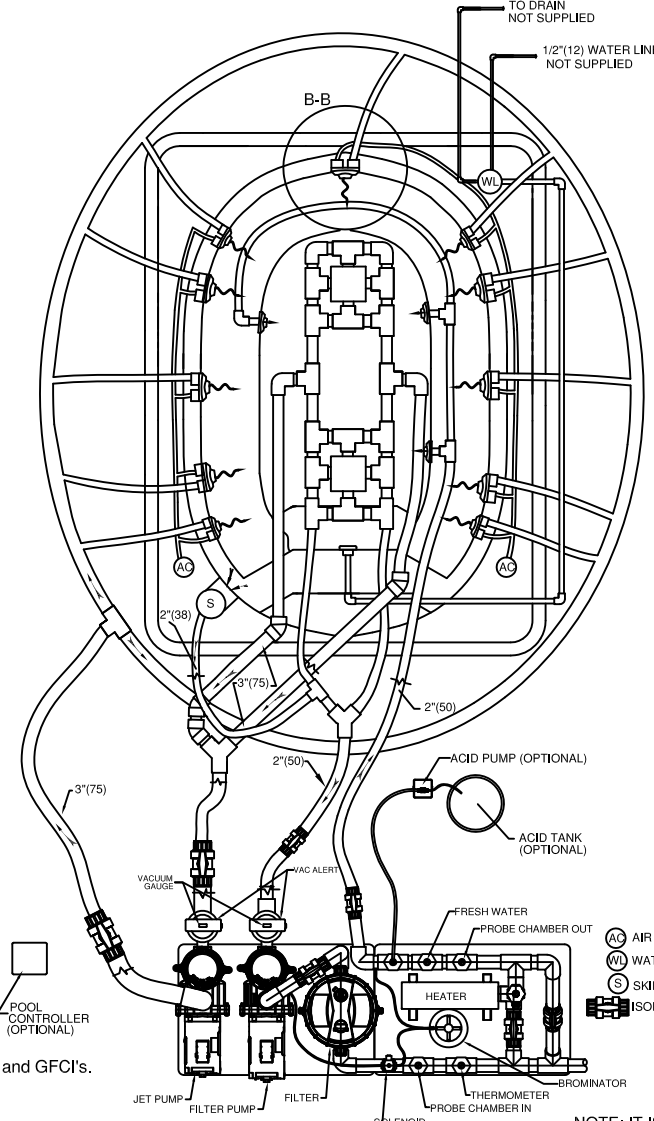

HYDRAULIC DESIGN

SPA VOLUME 650 usg
2461 Litre
TURNOVER 14.5 minutes
FILTER FLOW RATE 45 usgpm @ 60' T.D.H.
170.3 LPM @ 17.92 M hd
FILTER AREA 150 sq.ft.
13.9 sq.m.
OPERATING @.30 usgpm/sq.ft.
@ .20 L / S/ M²
FILTER PUMP 3/4 hp

11 HYDROTHERAPY FITTINGS
7 LARGE OPERATING @ 13 usgpm/ 49.2 Lpm
4 SMALL OPERATING @ 6 usgpm/ 22.7 Lpm
HYDROTHERAPY FLOW RATE 115 usgpm @ 60' TDH
435.3 LPM @ 17.92 M hd
HYDROTHERAPY PUMP 3 hp

TOTAL FLOW RATE 160 usgpm/ 605.6 Lpm
TOTAL OPEN AREA OF MAIN DRAINS 86.5 sq.in./ 557.4 sq.cm.
VELOCITY THROUGH MAIN DRAINS .59 ft.sec/ 0.1798 m. sec

*Optional Sand Filter Available upon request please discuss with a Hydrother Representative

NOTE: IT IS THE RESPONSIBILITY OF THE INSTALLER/OWNER TO VERIFY THAT THE SPA, EQUIPMENT AND SYSTEMS COMPLY WITH CODE REQUIREMENTS.